

Features

- Increase in DC pressure ratings to AC levels on all products (up to a 500% improvement)
- Lower power operation
- Voltage ranging
- Built in surge suppression
- Elimination of AC hum
- Increase in AC and DC operating temperatures
- Low solenoid temperature rise
- Longer coil life due to lower operating temperatures and electrical surge suppression
- Solenoid approvals to UL, CSA, and CE directives
- Available with Class I, Division 2 coils (EE prefix)

Nominal Ambient Temp. Ranges

-14°F to 140°F (-10°C to 60°C)

How to order

Find the valve that you are looking for in the provided specifications tables.

The tables contain the following information designed to help you in making your selection:

Pipe Size (in)	Orifice Dia. (in)	Cv Flow	Operating Pressure Differential (psi)				Max Fluid Temp. °F	Brass ①	Const. Ref.	Agency		Stainless Steel	Const. Ref.	Agency		Wattage AC/DC	Approx. Shipping Weight (lbs.)
			Max. AC/DC			UL				UL							
			Min.	Air-Inert Gas	Water						Light Oil @ 300 SSU						
1/2	5/8	4	0	150	150	-	180	8210P094	4	○	-	-	-	-	2	3.2	

① When ordering a valve product, specify the ASCO base catalog number (Ex. **8210P094**). This number will always be 8 digits long.

Choose one of the three operating voltage ranges (100-240V/50-60Hz/DC, 24-99V/50-60Hz/DC or 12-24/DC) and add it to the base catalog number (Ex. 8210P094 **24-99V/50-60Hz/DC**).

If you want to enhance the product with one or more of the options allowed in the Optional Features Chart for that catalog number, please add the appropriate prefix or suffix (as shown):

Pipe Size (in)	Orifice Dia. (in)	Solenoid Options ②	Base Catalog Number		Resilient Materials ③								Other ③		Standard Rebuild Kit ④	
		Class I, Division 2 Coil	Brass	Stainless Steel	NBR	FKM	EPDM	CR	Oxygen Service	PTFE	Urethane	Vacuum	Manual Operator	Mounting Bracket	Brass AC/DC	Stainless Steel AC/DC
1/2	5/8	EE	8210P094	-	●	V	E	J	N	-	-	VH	MO	MB	322670	-

② Optional Class I, Division 2 solenoid (Ex. **EE8210P094** 24-99V/50-60Hz/DC)

③ If an FKM elastomer and manual operator are required, add VMO to the back of the base catalog number. (Ex. 8210P094**VMO** 24-99V/50-60Hz/DC)

④ When ordering a rebuild kit for a valve, supply the rebuild kit number as shown in the table. (Ex. 322670) When ordering a rebuild kit for a valve with a suffix, add the suffix to the appropriate standard rebuild kit. (Ex. The rebuild kit for the above valve with FKM is 322670-V)

All constructions are available with prefix EE for Class I, Division 2 requirements.

When ordering a replacement coil, select from the following:

Voltage Range	Valve Prefix	Replacement Coil Part Number
100-240V/50-60Hz/DC	-	250404-601-*
24-99V/50-60Hz/DC	-	250404-602-*
12-24/DC	-	250404-603-*
100-240V/50-60Hz/DC	EE	250504-601-*
24-99V/50-60Hz/DC	EE	250504-602-*
12-24/DC	EE	250504-603-*

Solenoid Enclosures

Standard: Watertight, Types 1, 2, 3, 3S, 4, and 4X.

Optional: Class I, Division 2 for Hazardous Locations and Watertight, Types 3, 3S, 4, 4X. (To order, add prefix "EE" to catalog number.)

Note

See Engineering Section for valve parts in contact with fluids and additional information.



ELECTRONICALLY ENHANCED

2-Way Features

- Two-way (2/2) Next Generation solenoid valves have one inlet port and one outlet port
- Control of air, water, light oil, and non-corrosive media
- Normally closed (opens when energized) and normally open (closed when energized) operation
- Pipe sizes – 1/8 to 2 inch

2-Way Specifications (English units)

Pipe Size (in)	Orifice Dia. (in)	Cv Flow	Operating Pressure Differential (psi)				Max Fluid Temp. °F	Brass	Const. Ref.	Agency		Stainless Steel	Const Ref.	Agency		Wattage AC/DC
			Min.	Max. AC/DC						UL	UL					
				Air-Inert Gas	Water	Light Oil @ 300 SSU										
General Service - Normally Closed																
1/8	3/64	0.06	0	2200	2200	1700	140	-	-	-	8262R175 ⑤	1	●	-	2	
1/8	3/64	0.06	0	1500	1500	1500	140	8262R099 ⑤	1	●	-	-	-	-	2	
1/8	3/32	0.21	0	720	410	410	180	8262R277	1	○	8262R178	1	○	-	2	
1/8	1/8	0.35	0	540	395	360	180	8262R105	1	○	8262R174	1	○	-	2	
1/8	1/8	0.35	0	200	-	-	167	8262R077 ⑥	1	○	-	-	-	-	2	
1/4	3/64	0.06	0	1500	1500	1500	140	8262R107 ⑤	2	●	-	-	-	-	2	
1/4	3/64	0.06	0	2200	2200	1700	140	-	-	-	8262R181 ⑤	2	●	-	2	
1/4	3/32	0.21	0	720	410	410	180	8262R109	2	○	8262R183	2	○	-	2	
1/4	1/8	0.35	0	540	395	360	180	8262R232	2	○	8262R185	2	○	-	2	
1/4	5/32	0.52	0	300	225	225	180	8262R202	2	○	8262R220	2	○	-	2	
1/4	7/32	0.73	0	125	125	125	180	8262R208	2	○	8262R226	2	○	-	2	
1/4	9/32	0.88	0	105	105	105	180	8262R212	2	○	8262R230	2	○	-	2	
1/4	9/32	1.0	0	50	-	-	167	8262R078 ⑥	2	○	-	-	-	-	2	
1/4	5/16	1.5	10	1500	1500	1500	180	8223P025	18	-	-	-	-	-	2	
3/8	1/8	0.35	0	540	395	360	180	8263R115	3	○	8263R191	3	○	-	2	
3/8	5/32	0.52	0	300	225	225	180	8263R200	3	○	8263R193	3	○	-	2	
3/8	7/32	0.73	0	125	125	125	180	8263R124	3	○	8263R332	3	○	-	2	
3/8	9/32	0.88	0	105	85	85	180	8263R210	3	○	8263R333	3	○	-	2	
3/8	5/16	1.5	10	1500	1500	1500	180	8223P027	18	-	-	-	-	-	2	
3/8	5/8	3	0	150	150	-	180	8210P093	4	○	-	-	-	-	2	
3/8	5/8	3	5	300	300	300	180	8210P006	4	●	-	-	-	-	2	
1/2	3/8	3.2	25	1500	1500	1500	180	8223P003	5	-	8223P010	6	-	-	2	
1/2	5/8	4	0	150	150	-	180	8210P094	4	○	-	-	-	-	2	
1/2	5/8	4	0	150	150	125	180	-	-	-	8210P087	7	●	-	2	
1/2	5/8	4	5	300	300	300	180	8210P007	4	○	-	-	-	-	2	
3/4	5/8	4.5	0	150	150	125	180	-	-	-	8210P088	7	●	-	2	
3/4	3/4	5	0	150	150	-	180	8210P095	7	○	-	-	-	-	2	
3/4	3/4	5	0	3	3	-	180	8030P003	8	○	-	-	-	-	2	
3/4	3/4	7.8	25	750	750	750	180	8223P005	9	-	-	-	-	-	2	
1	1	13	5	150	150	100	180	8210P004	10	○	-	-	-	-	2	
1 1/4	1 1/8	15	5	150	150	100	180	8210P008	10	○	-	-	-	-	2	
1 1/2	1 1/4	22.5	5	150	150	100	180	8210P022	11	○	-	-	-	-	2	
2	1 3/4	43	5	150	125	90	180	8210P100	12	●	-	-	-	-	2	
General Service - Normally Open																
1/8	3/64	0.06	0	1150	900	800	140	8262R155 ⑤	13	●	8262R168 ⑤	13	●	-	2	
1/8	3/64	0.06	0	750	750	750	180	8262R156	13	●	8262R169	13	●	-	2	
1/8	3/32	0.21	0	275	230	180	180	8262R128	13	●	8262R236	13	●	-	2	
1/8	1/8	0.35	0	160	145	125	180	8262R129	13	●	8262R237	13	●	-	2	
1/4	3/64	0.06	0	1150	900	800	140	8262R161 ⑤	14	●	8262R199 ⑤	14	●	-	2	
1/4	3/64	0.06	0	750	750	750	180	8262R260	14	●	8262R130	14	●	-	2	
1/4	3/32	0.21	0	275	230	180	180	8262R261	14	●	8262R134	14	●	-	2	
1/4	1/8	0.35	0	160	145	125	180	8262R262	14	●	8262R138	14	●	-	2	
1/4	5/32	0.54	0	90	90	70	180	8262R263	14	●	8262R142	14	●	-	2	
1/4	7/32	0.83	0	45	45	40	180	8262R264	14	●	8262R148	14	●	-	2	
1/4	9/32	0.96	0	30	30	30	180	8262R265	14	●	8262R152	14	●	-	2	
3/8	1/8	0.35	0	160	145	125	180	8263R070	18	●	8263R080	18	●	-	2	
3/8	5/32	0.54	0	90	90	70	180	8263R071	18	●	8263R081	18	●	-	2	
3/8	7/32	0.83	0	45	45	40	180	8263R072	18	●	8263R082	18	●	-	2	
3/8	9/32	0.96	0	30	30	30	180	8263R073	18	●	8263R083	18	●	-	2	

○ = Safety Shut-off Valve. ● = General Purpose Valve

ELECTRONICALLY ENHANCED

2-Way Specifications (Metric units)

Pipe Size (in)	Orifice Dia. (mm)	Kv Flow	Min.	Operating Pressure Differential (bar)			Max Fluid Temp. °C	Brass	Const. Ref.	Agency	Stainless Steel	Const. Ref.	Agency	Wattage AC/DC
				Max. AC/DC										
				Air-Inert Gas	Water	Light Oil @ 300 SSU								
General Service - Normally Closed														
1/8	1.2	0.05	0	152	152	117	60	-	-	-	8262R175 ⑤	1	●	2
1/8	1.2	0.05	0	103	103	103	60	8262R099 ⑤	1	●	-	-	-	2
1/8	2.4	0.18	0	50	28	28	82	8262R277	1	○	8262R178	1	○	2
1/8	3.2	0.30	0	37	27	25	82	8262R105	1	○	8262R174	1	○	2
1/8	3.2	0.30	0	14	-	-	75	8262R077 ⑥	1	○	-	-	-	2
1/4	1.2	0.05	0	103	103	103	60	8262R107 ⑤	2	●	-	-	-	2
1/4	1.2	0.05	0	152	152	117	60	-	-	-	8262R181 ⑤	2	●	2
1/4	2.4	0.18	0	50	28	28	82	8262R109	2	○	8262R183	2	○	2
1/4	3.2	0.30	0	37	27	25	82	8262R232	2	○	8262R185	2	○	2
1/4	4.0	0.45	0	21	16	16	82	8262R202	2	○	8262R220	2	○	2
1/4	5.6	0.63	0	9	9	9	82	8262R208	2	○	8262R226	2	○	2
1/4	7.1	0.76	0	7	7	7	82	8262R212	2	○	8262R230	2	○	2
1/4	7.1	0.74	0	3	-	-	75	8262R078 ⑥	2	○	-	-	-	2
1/4	7.9	1.3	.7	103	103	103	82	8223P025	18	-	-	-	-	2
3/8	3.2	0.30	0	37	27	25	82	8263R115	3	○	8263R191	3	○	2
3/8	4.0	0.45	0	21	16	16	82	8263R200	3	○	8263R193	3	○	2
3/8	5.6	0.63	0	9	9	9	82	8263R124	3	○	8263R332	3	○	2
3/8	7.1	0.76	0	7	6	6	82	8263R210	3	○	8263R333	3	○	2
3/8	7.9	1.3	.7	103	103	103	82	8223P027	18	-	-	-	-	2
3/8	16	2.6	0	10	10	-	82	8210P093	4	○	-	-	-	2
3/8	16	2.6	0.3	21	21	21	82	8210P006	4	●	-	-	-	2
1/2	9.5	2.7	1.7	103	103	103	82	8223P003	5	-	8223P010	6	-	2
1/2	16	3.4	0	10	10	-	82	8210P094	4	○	-	-	-	2
1/2	16	3.4	0	10	10	9	82	-	-	-	8210P087	7	●	2
1/2	16	3.4	0.3	21	21	21	82	8210P007	4	○	-	-	-	2
3/4	16	3.9	0	10	10	9	82	-	-	-	8210P088	7	●	2
3/4	19	4.3	0	10	10	-	82	8210P095	7	○	-	-	-	2
3/4	19	4.3	0	0.2	0.2	-	82	8030P003	8	○	-	-	-	2
3/4	19	6.7	1.7	52	52	52	82	8223P005	9	-	-	-	-	2
1	25	11	0.3	10	10	7	82	8210P004	10	○	-	-	-	2
1 1/4	29	13	0.3	10	10	7	82	8210P008	10	○	-	-	-	2
1 1/2	32	19	0.3	10	10	7	82	8210P022	11	○	-	-	-	2
2	44	37	0.3	10	9	6	82	8210P100	12	●	-	-	-	2
General Service - Normally Open														
1/8	1.20	0.05	0	79	62	55	60	8262R155 ⑤	13	●	8262R168 ⑤	13	●	2
1/8	1.20	0.05	0	52	52	52	82	8262R156	13	●	8262R169	13	●	2
1/8	2.40	0.18	0	19	16	12	82	8262R128	13	●	8262R236	13	●	2
1/8	3.20	0.30	0	11	10	9	82	8262R129	13	●	8262R237	13	●	2
1/4	1.20	0.05	0	79	62	55	60	8262R161 ⑤	14	●	8262R199 ⑤	14	●	2
1/4	1.20	0.05	0	52	52	52	82	8262R260	14	●	8262R130	14	●	2
1/4	2.40	0.18	0	19	16	12	82	8262R261	14	●	8262R134	14	●	2
1/4	3.20	0.30	0	11	10	9	82	8262R262	14	●	8262R138	14	●	2
1/4	3.90	0.47	0	6	6	5	82	8262R263	14	●	8262R142	14	●	2
1/4	5.60	0.72	0	3	3	3	82	8262R264	14	●	8262R148	14	●	2
1/4	7.10	0.83	0	2	2	2	82	8262R265	14	●	8262R152	14	●	2
3/8	3.20	0.30	0	11	10	9	82	8263R070	18	●	8263R080	18	●	2
3/8	3.90	0.47	0	6	6	5	82	8263R071	18	●	8263R081	18	●	2
3/8	5.60	0.72	0	3	3	3	82	8263R072	18	●	8263R082	18	●	2
3/8	7.10	0.83	0	2	2	2	82	8263R073	18	●	8263R083	18	●	2

○ = Safety Shut-off Valve. ● = General Purpose Valve

ELECTRONICALLY ENHANCED

2-Way Optional Features Chart

Pipe Size (in)	Orifice Dia. (in)	Base Catalog Number		Resilient Materials and Suffix Options												Other		Standard Rebuild Kit	
		Brass	Stainless Steel	Ammonia ⑦	Silicone Free	Dry Air	NBR	LT NBR	FKM	EPDM	CR	Oxygen Service	PTFE ②	Urethane	Vacuum	Manual Operator	Mounting Bracket	Brass AC/DC	Stainless Steel AC/DC
1/8	3/64	8262R099 ⑤	8262R175 ⑤	-	SF	-	-	-	-	-	-	-	●	-	-	MB	323593-W	323595-W	
1/8	3/64	8262R155 ⑤	8262R168 ⑤	-	SF	-	-	-	-	-	-	-	●	-	-	MB	323986-W	323988-W	
1/8	3/64	8262R156	8262R169	NH	SF	-	●	A	V	E	J	N	T	-	-	MB	323986	323988	
1/8	3/32	8262R277	8262R178	NH	SF	-	●	A	V	E	J	N	T	-	-	MS	MB	323593	323595
1/8	3/32	8262R128	8262R236	NH	SF	-	●	A	V	E	J	N	T	-	-	MB	323987	323989	
1/8	1/8	8262R105	8262R174	NH	SF	-	●	A	V	E	J	N	T	-	VH	MS	MB	323593	323595
1/8	1/8	8262R077 ⑥	-	-	SF	-	-	●	-	-	-	-	-	-	-	MB	325039	-	
1/8	1/8	8262R129	8262R237	NH	SF	-	●	A	V	E	J	N	T	-	VH	MB	323987	323989	
1/4	3/64	8262R107 ⑤	8262R181 ⑤	-	SF	-	-	-	-	-	-	-	●	-	-	MB	323593-W	323595-W	
1/4	3/64	8262R161 ⑤	8262R199 ⑤	-	SF	-	-	-	-	-	-	-	●	-	-	MB	323986-W	323988-W	
1/4	3/64	8262R260	8262R130	NH	SF	-	●	A	V	E	J	N	T	-	-	MB	323986	323988	
1/4	3/32	8262R109	8262R183	NH	SF	P	●	A	V	E	J	N	T	-	-	MS	MB	323593	323595
1/4	3/32	8262R261	8262R134	NH	SF	-	●	A	V	E	J	N	T	-	-	MB	323987	323989	
1/4	1/8	8262R232	8262R184	NH	SF	P	●	A	V	E	J	N	T	-	-	MS	MB	323593	323595
1/4	1/8	8262R262	8262R138	NH	SF	-	●	A	V	E	J	N	T	-	-	MB	323987	323989	
1/4	5/32	8262R202	8262R220	NH	SF	P	●	A	V	E	J	N	T	-	-	MS	MB	323593	323595
1/4	5/32	8262R263	8262R142	NH	SF	-	●	A	V	E	J	N	T	-	-	MB	323987	323989	
1/4	7/32	8262R208	8262R226	NH	SF	P	●	A	V	E	J	N	T	-	-	MS	MB	323593	323595
1/4	7/32	8262R264	8262R148	NH	SF	-	●	A	V	E	J	N	T	-	-	MB	323987	323989	
1/4	9/32	8262R212	8262R230	NH	SF	P	●	A	V	E	J	N	T	-	VH	MS	MB	323593	323595
1/4	9/32	8262R265	8262R152	NH	SF	-	●	A	V	E	J	N	T	-	VH	MB	323987	323989	
1/4	9/32	8262R078 ⑥	-	-	SF	-	-	●	-	-	-	-	-	-	-	MB	325039	-	
1/4	5/16	8223P025 ④	-	-	-	-	●	A	-	-	-	-	-	-	-	-	322815	-	
3/8	1/8	8263R115	8263R191	NH	SF	-	●	A	V	E	J	N	T	-	-	MS	MB	323593	323595
3/8	1/8	8263R070	8263R080	NH	SF	-	●	A	V	E	J	N	T	-	-	MB	323987	323989	
3/8	5/32	8263R200	8263R193	NH	SF	-	●	A	V	E	J	N	T	-	-	MS	MB	323593	323595
3/8	5/32	8263R071	8263R081	NH	SF	-	●	A	V	E	J	N	T	-	-	MB	323987	323989	
3/8	7/32	8263R124	8263R332	NH	SF	-	●	A	V	E	J	N	T	-	-	MS	MB	323593	323595
3/8	7/32	8263R072	8263R082	NH	SF	-	●	A	V	E	J	N	T	-	-	MB	323987	323989	
3/8	9/32	8263R210	8263R333	NH	SF	-	●	A	V	E	J	N	T	-	-	MS	MB	323593	323595
3/8	9/32	8263R073	8263R083	NH	SF	-	●	A	V	E	J	N	T	-	-	MB	323987	323989	
3/8	5/16	8223P027 ④	-	-	-	-	●	-	-	-	-	-	-	-	-	-	322815	-	
3/8	5/8	8210P093	-	-	-	-	●	-	V	E	J	N	-	-	VH	MO	MB	322670	-
3/8	5/8	8210P033	-	-	-	-	●	-	V	E	J	N	-	-	VH	MB	322770	-	
3/8	5/8	8210P006	-	-	-	-	●	-	V	E	J	N	-	-	-	MO	MB	322654	-
1/2	3/8	8223P003 ④	8223P010 ①	-	-	-	●	-	-	-	-	-	-	-	-	-	322816	322817	
1/2	5/8	8210P094	-	-	-	-	●	-	V	E	J	N	-	-	VH	MO	MB	322670	-
1/2	5/8	8210P034	-	-	-	-	●	-	V	E	J	N	-	-	VH	MB	322770	-	
1/2	5/8	-	8210P087	-	-	-	●	-	V	E	J	N	-	-	-	MO	MB	-	322676
1/2	5/8	8210P007	-	-	-	-	●	-	V	E	J	N	-	-	-	MO ③	MB	322654	-
3/4	5/8	-	8210P088	-	-	-	●	-	V	E	J	N	-	-	-	MO	MB	-	322676
3/4	3/4	8210P095	-	-	-	-	●	-	V	E	J	N	-	-	VH	MO	MB	322673	-
3/4	3/4	8030P003	-	-	-	-	●	-	V	E	J	N	-	-	-	MO	MB	322758	-
3/4	3/4	8210P035	-	-	-	-	●	-	V	E	J	N	-	-	VH	MB	322771	-	
3/4	3/4	8030P083	-	-	-	-	●	-	V	E	J	N	-	-	-	MB	322763	-	
3/4	3/4	8223P005 ④	-	-	-	-	●	-	-	-	-	-	-	-	-	-	322818	-	
1	1	8210P004	-	-	-	-	●	-	V	E	J	N	-	-	-	MO	-	322677	-
1 1/4	1 1/8	8210P008	-	-	-	-	●	-	V	E	J	N	-	-	-	MO	-	322680	-
1 1/2	1 1/4	8210P022	-	-	-	-	●	-	V	E	J	N	-	-	-	MO	-	322680	-
2	1 3/4	8210P100	-	-	-	-	●	-	V	E	J	N	-	-	-	MO	-	322682	-

● = Standard. Other options may be available. All option combinations may not be available. Please consult your local ASCO contact.
 ① Valve contains PTFE main disc; ② Pressure rating reduced by 25%; ③ Pressure rating limited to 250 psi; ④ Valve contains Nylon 11 piston.
 ⑤ Cast UR disc supplied as standard, limits min. ambient temp. to 32°F (0°C). ⑥ Fuel gas service only; Ambient Temp. -40°F to 140°F, Fluid Temp. -40°F to 167°F; Gas capacity for 8262R077 is 18,700 Btu/hr, for 8262R078 53,500 Btu/hr based on 1" W.C. Drop @ 2" W.C. Inlet Pressure, 1000 Btu/cu.ft. or more, 0.64 Specific Gravity Gas.
 ⑦ NH suffix only available for Stainless Steel constructions.

ELECTRONICALLY ENHANCED

Dimensions: inches (mm)

Const. Ref.		B	C	D	E	F	G	H	I
1	in	3.98	3.04	2.00	0.69	1.00	1.19	1.87	1.24
	mm	101	77	51	18	25	30	48	32
2	in	3.98	3.04	2.00	0.78	1.11	1.56	1.87	1.29
	mm	101	77	51	20	29	40	48	33
3	in	3.98	3.04	2.00	0.77	1.20	1.88	1.87	1.25
	mm	101	77	51	20	30	48	48	32
4	in	3.98	3.04	2.00	1.28	1.84	2.75	1.87	2.28
	mm	101	77	51	33	47	70	48	58
5	in	3.98	3.04	2.00	1.05	2.31	-	1.87	3.03
	mm	101	77	51	27	59	-	48	77
6	in	3.98	3.04	2.00	1.13	2.31	-	1.87	3.13
	mm	101	77	51	29	59	-	48	80
7	in	3.98	3.04	2.00	1.46	2.19	2.81	1.87	2.28
	mm	101	77	51	37	56	71	48	58
8	in	3.98	3.04	2.00	1.44	2.13	2.81	1.87	2.28
	mm	101	77	51	37	54	71	48	58
9	in	3.98	3.04	2.00	1.61	3.03	-	1.87	3.6
	mm	101	77	51	41	77	-	48	91
10	in	3.98	3.04	2.00	2.21	3.67	3.75	1.87	-
	mm	101	77	51	56	93	95	48	-
11	in	3.98	3.04	2.00	2.36	4.14	4.38	1.87	3.92
	mm	101	77	51	60	105	111	48	100
12	in	3.98	3.04	2.00	2.75	5.52	5.06	1.87	4.72
	mm	101	77	51	70	140	129	48	120
13	in	3.98	3.04	2.00	0.69	1.00	1.19	1.87	1.24
	mm	101	77	51	18	25	30	48	32
14	in	3.98	3.04	2.00	0.78	1.11	1.56	1.87	1.29
	mm	101	77	51	19.7	29	40	48	33
15	in	3.98	3.04	2.00	1.72	2.18	2.75	1.87	2.28
	mm	101	77	51	44	55	70	48	58
16	in	3.98	3.04	2.00	1.88	2.57	2.81	1.87	2.28
	mm	101	77	51	48	65	71	48	58
17	in	3.98	3.04	2.00	0.85	1.81	2.81	1.87	2.28
	mm	101	77	51	22	46	71	48	58
18	in	3.98	3.04	2.00	0.77	1.20	1.88	1.87	1.25
	mm	101	77	51	20	30	48	48	32

Const. Ref. 1

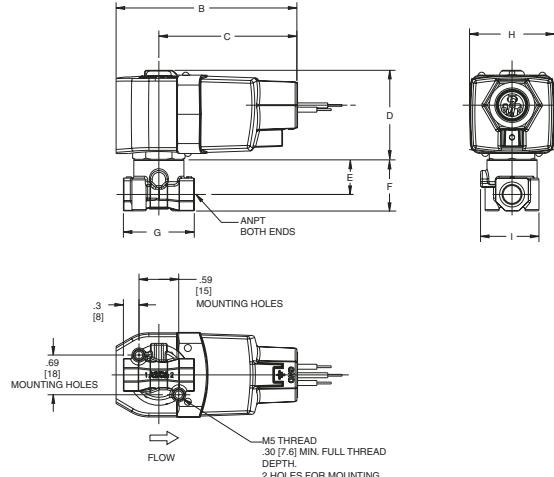

Const. Ref. 2

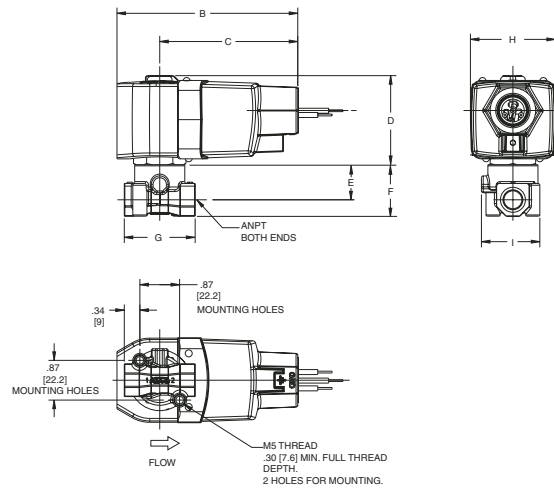

Const. Ref. 3

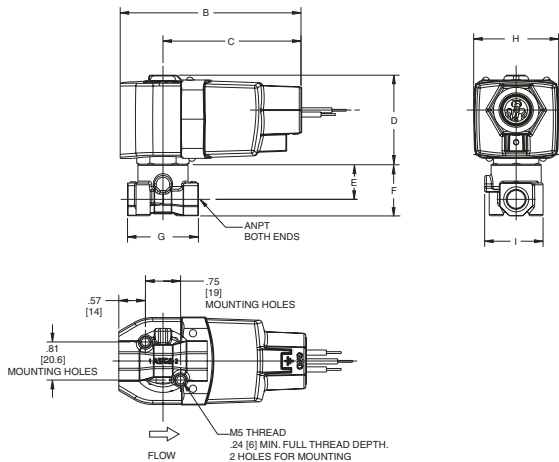

Const. Ref. 4, 7, 15, 16, 17

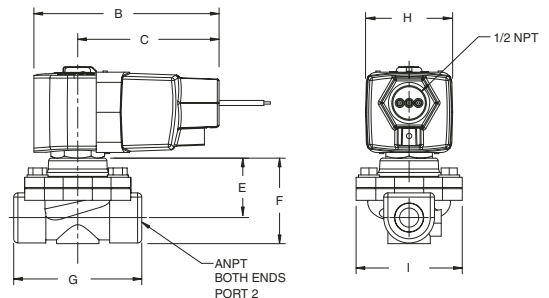

ELECTRONICALLY ENHANCED

Dimensions: inches (mm)

ELECTRONICALLY
 ENHANCED

Const. Ref. 5, 6, 9

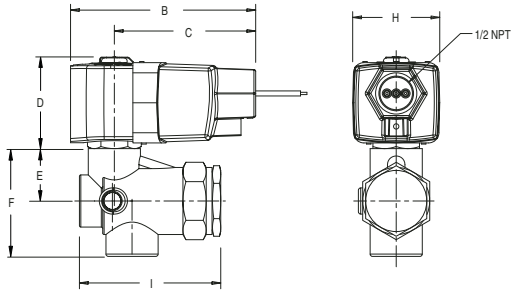

Const. Ref. 8

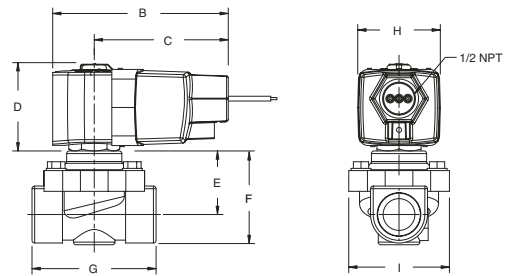

Const. Ref. 10

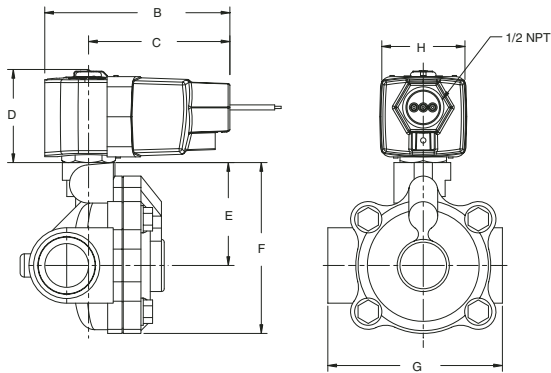

Const. Ref. 11, 12

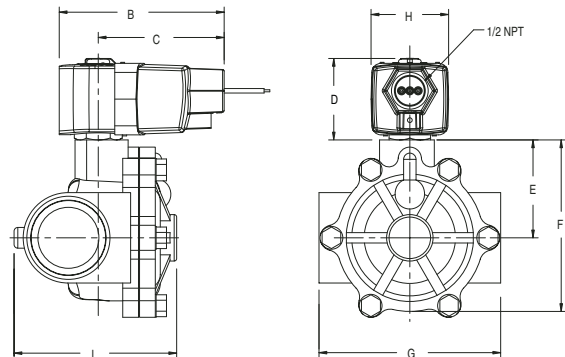

Const. Ref. 13, 14

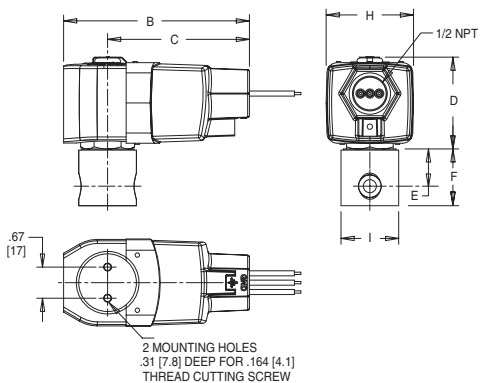

Const. Ref. 18

