

Features

- Manual reset versions of sturdy ASCO 8342 Series (1/4" and 3/8" NPT) and Series 8344 (1/2" to 1" NPT)
- 1/4" and 3/8" NPT are direct acting to provide maximum flow for their size
- 1/2" to 1" NPT have Poppet construction for high flows and tight shutoff
- Once tripped, can only be manually reset to automatic operation
- Electrically Tripped (trips when energized), No Voltage Release (trips when de-energized), or Free Handle constructions
- Intrinsically Safe constructions are available

Construction

Valve Parts in Contact with Fluids	
Body	Brass
Stem	303 Stainless Steel
Springs	302 Stainless Steel
Pilot Seat Cartridge	CA (when listed)
Disc, Diaphragm, Seat	PTFE, FKM, or NBR (as listed)

Electrical

Standard Coil and Class of Insulation	Watt Rating and Power Consumption				Spare Coil Part Number	
	DC Watts	AC			AC	DC
		Watts	VA Holding	VA Inrush		
F	-	20	45	96	99257	-
H	36.2	-	-	-	-	222184

Standard Voltages: 24, 120, 240, 480 volts AC, 60 Hz. 6, 12, 24, 120, 240 volts DC. Must be specified when ordering. Other voltages are available when required.

Note: 125 and 250 volts DC are battery voltages applied in power plants. Special valves are available to pilot control valves in power plants. Consult your local ASCO sales office for a listing.

Solenoid Enclosures

Standard: RedHat metal solenoid enclosure. Type 1 General Purpose Junction Box.

Optional: Explosionproof and Watertight, Types 3, 7 (C and D), and 9. (To order, add prefix "EF" to catalog number.)

See *Optional Features Section* for other available options.

Nominal Ambient Temp. Ranges

AC: -20°F to 104°F (-29°C to 40°C)

Refer to *Engineering Section* for details.

Approvals

CSA certified. Some constructions meet shock and vibration ISA S71.03C2

Refer to *Engineering Section* for details.

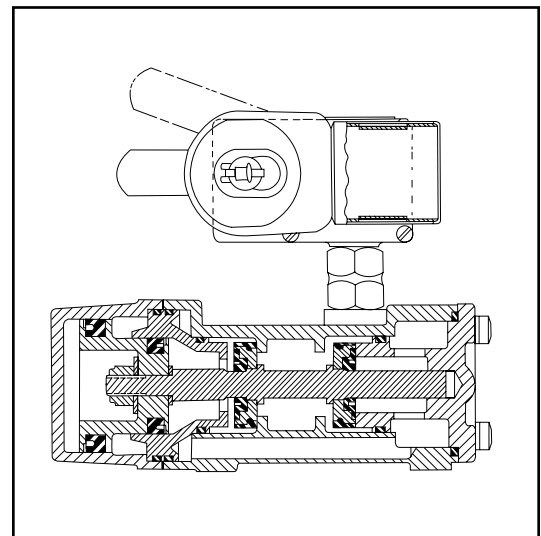
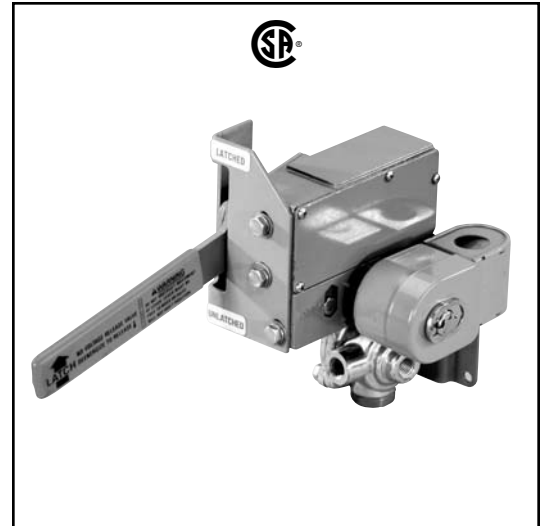

SPECIAL SERVICE PILOT

Operation Alternatives

Electrically Tripped – Valves move to latched position when the solenoid is de-energized, trips when they receive a continuous or momentary (at least 0.3 seconds) electrical signal. When tripped, they can be manually cycled open/closed, but must be reset when the solenoid has once again been de-energized.

No Voltage Release – Valves move to latched position when the solenoid is energized, trips when de-energized. When tripped, they can be manually cycled open/closed, but must be reset when the solenoid has once again been energized.

Free Handle – Valves move to latched position when the solenoid is energized, trips when de-energized. They cannot be manually cycled open/closed when de-energized. They can be manually cycled open/closed or reset only when energized.

Specifications (English units)

Pipe Size (ins.)	Orifice Size (ins.)	Cv Flow Factor	Operating Pressure Differential (psi)			Max. Fluid Temp. °F		No Voltage Release Catalog Number	Electrically Tripped Catalog Number	Const. Ref.	Watt Rating/ Class of Coil Insulation	
			Min.	Max. AC	Max. DC	AC	DC				AC	DC
BRASS BODY with PTFE + FKM Seats and Discs for Air and Inert Gas												
1/4	3/16	.70	0	250	250	160	160	8408B006	8410B006	1	20/F	36.2/H
3/8	3/16	.70	0	250	250	160	160	8408B007	8410B007	1	20/F	36.2/H
BRASS BODY with NBR Seats and Discs (CA Pilot Cartridge) for Air, Inert Gas, Water, and Light Oil. This group of valves meets shock and vibration ISA S71.03C2.												
1/2	3/8	2.2	10	250	250	200	200	8408A008 ①	8410A008 ①	4	20/F	36.2/H
3/4	3/4	5.6	10	250	250	200	200	8408A009 ①	8410A009 ①	3	20/F	36.2/H
1	3/4	5.6	10	250	250	200	200	8408A010 ①	8410A010 ①	3	20/F	36.2/H
BRASS BODY with PTFE + FKM Seats and Discs for Air								Free Handle Construction				
1/4	3/16	.70	0	125	125	160	160	8047A001		2	20/F	36.2/H
3/8	3/16	.70	0	125	125	160	160	8047A002		2	20/F	36.2/H
① A Minimum Operating Pressure Differential must be maintained between the pressure and exhaust ports. Supply and exhaust piping must be full area, unrestricted. ASCO flow controls and other similar components must be installed in the cylinder lines only.												

Specifications (Metric units)

Pipe Size (ins.)	Orifice Size (mm)	Kv Flow Factor (m3/h)	Operating Pressure Differential (bar)			Max. Fluid Temp. °C		No Voltage Release Catalog Number	Electrically Tripped Catalog Number	Const. Ref.	Watt Rating/ Class of Coil Insulation	
			Min.	Max. AC	Max. DC	AC	DC				AC	DC
BRASS BODY with PTFE + FKM Seats and Discs for Air and Inert Gas												
1/4	5	.60	0	17	17	71	71	8408B006	8410B006	1	20/F	36.2/H
3/8	5	.60	0	17	17	71	71	8408B007	8410B007	1	20/F	36.2/H
BRASS BODY with NBR Seats and Discs (CA Pilot Cartridge) for Air, Inert Gas, Water, and Light Oil. This group of valves meets shock and vibration ISA S71.03C2.												
1/2	10	1.89	0.7	17	17	93	93	8408A008 ①	8410A008 ①	4	20/F	36.2/H
3/4	19	4.80	0.7	17	17	93	93	8408A009 ①	8410A009 ①	3	20/F	36.2/H
1	19	4.80	0.7	17	17	93	93	8408A010 ①	8410A010 ①	3	20/F	36.2/H
BRASS BODY with PTFE + FKM Seats and Discs for Air								Free Handle Construction				
1/4	5	.60	0	9	9	71	71	8047A001		2	20/F	36.2/H
3/8	5	.60	0	9	9	71	71	8047A002		2	20/F	36.2/H
① A Minimum Operating Pressure Differential must be maintained between the pressure and exhaust ports. Supply and exhaust piping must be full area, unrestricted. ASCO flow controls and other similar components must be installed in the cylinder lines only.												

SPECIAL SERVICE PILOT

Dimensions inches (mm)

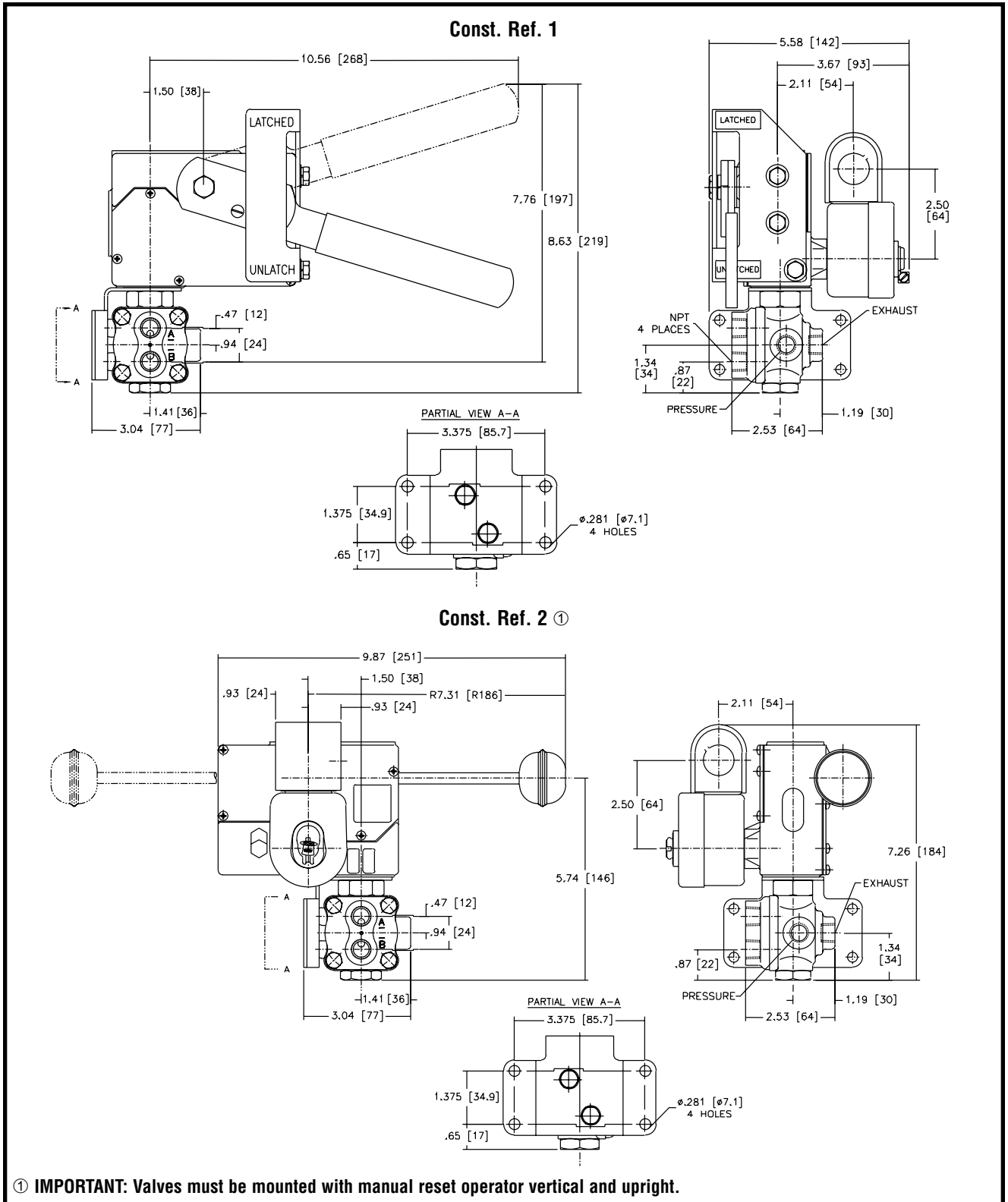

SPECIAL SERVICE PILOT

Dimensions inches (mm)

Const. Ref. 3
No Voltage Release

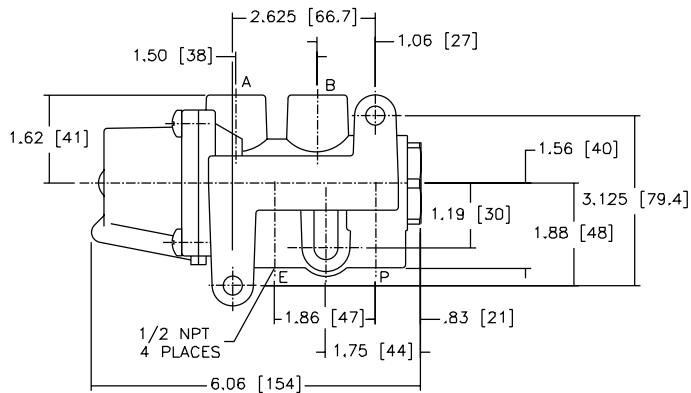
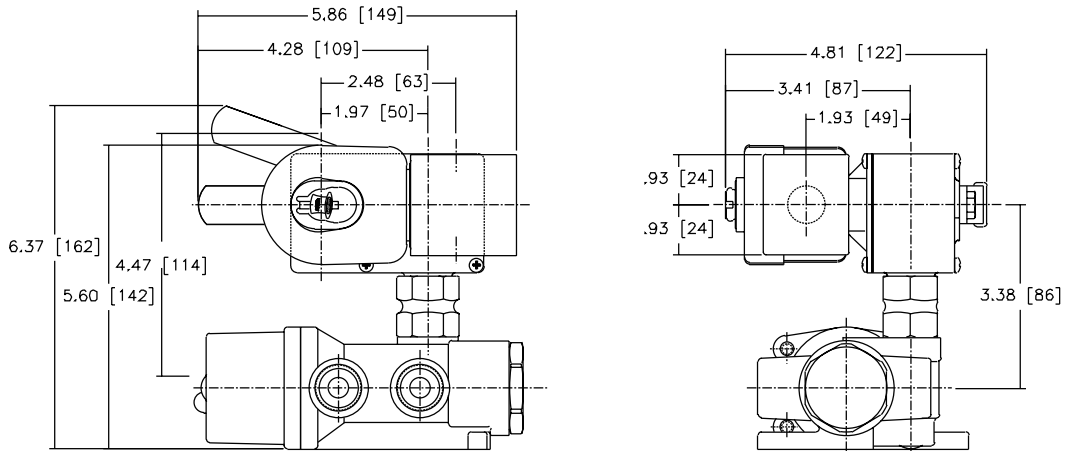

Const. Ref. 4
Electrically Tripped

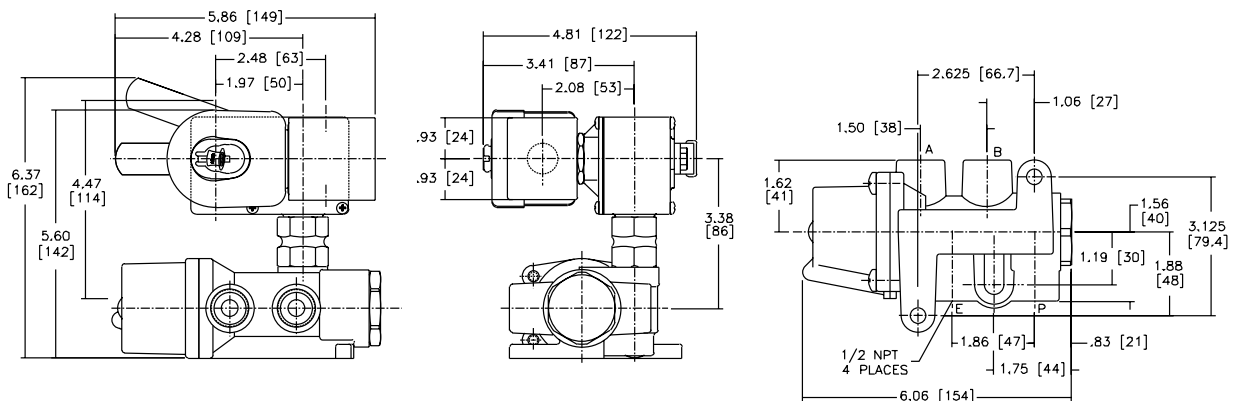

SPECIAL SERVICE
 PILOT